

Pulse Distribution Unit

Low Profile

1PPS, to 200 MHz, 2 in - 16 out, BNC

Issue 2

Part No: 10545



Pulse Distribution Unit

Part No: 10545

1PPS, to 200 MHz, 2 in - 16 out, BNC



Key features:

- 1pps time signal distribution
- Long distance transmission of pulse signals (1pps) with high delay stability and low jitter
- Compact design (1HU), rack mount
- High speed input comparator for signal restoration
- Short rise and fall times ($t_r, t_f < 500$ ps, 400 ps typ)
- Added jitter: < 2 ps
- Output to output skew: < 20 ps (10 ps typ)
- Instrument absolute delay: 6.5 ns nominal
- Temperature coefficient: 6 ps/K
- Matched to 50 Ohm
- BNC connectors
- DC coupled input for positive pulses, configurable trigger level
- AC coupled input for square wave input and for conversion of sine to square wave
- Usable for digital pulse distribution from below 1 PPS to 200 MHz
- AC and 2 x DC power supply inputs, automatic switch-over

Description

The Pulse Distribution Unit is a 1HU mount unit with very short rise and fall times, and provides 1 PPS (one pulse per second) pulses to 16 outputs. Together with a low temperature coefficient and very small channel-to-channel delay variation, this makes the unit ideal for high stability pulse distribution applications. Its fast input comparator accepts a wide range of input signals. Its trigger level can be set by rotary switch. The outputs are TTL signals when unloaded and 2.5 Vpp when loaded with 50 Ohm.

The unit is designed to use the rising edge as the significant pulse reference. A typical 1 PPS signal has a short pulse width only, but pulses of any duty cycle can be transmitted. The presence of input pulses is shown by an input LED indicator. A red ALRM LED shows an output failure or no signal present.

There are two selectable input connectors, both feature a high-speed input comparator:

- Input A is AC coupled for converting bipolar pulse or sine wave inputs into positive pulses. The trigger level is fixed at 0 V. Sine input will be converted to square wave of 50% duty cycle.
- Input B is DC coupled for distributing of positive pulses. The trigger level is configurable. It can be used to convert sinusoidal signals to square wave, with trigger set to 0V.

Pulse Distribution Unit

Part No: 10545

1PPS, to 200 MHz, 2 in - 16 out, BNC



Typical Waveforms

The signal outputs exhibit rise and fall times below 400 ps, shown below.

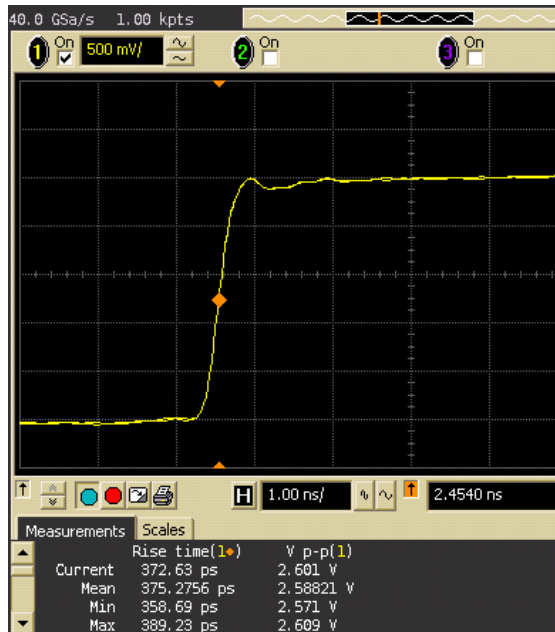

Fig 1a: Example rise time of 375 ps

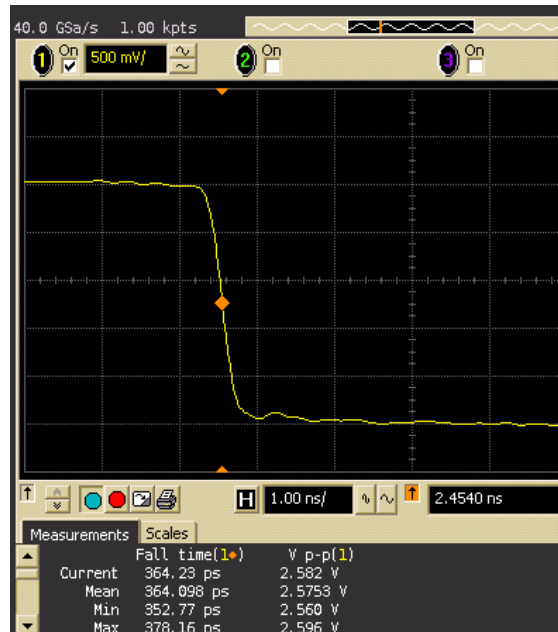

Fig 1b: Example fall time of 364 ps

- Test cable: 0.8 m ECOFLEX 10 (must have good RF characteristics)
- Scope bandwidth limited to 3 GHz
- **Long distance transmission example**

The transmission of a pulse signal over a distance of 310 m of FSJ1 cable using two units of 10545 is demonstrated.

A 310 m long high-stability co-axial cable (FSJ1) was connected in between two units as shown in Figure 2a. Performance was measured at the output of unit 2.

Setup:

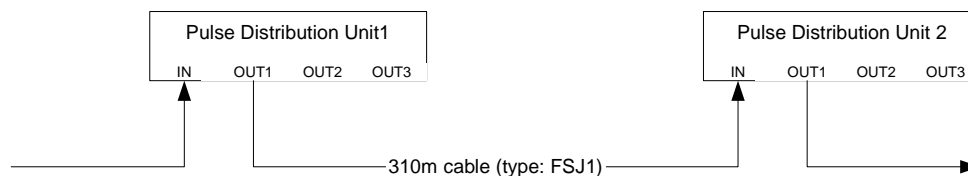

Fig 2a: Test setup

- Input to unit1: 1PPS signal (20 μ s width) from a 1 PPS generator (not shown)
- Trigger level of unit 2 = 0.6V
- All loads 50 Ω

Pulse Distribution Unit

Part No: 10545

1PPS, to 200 MHz, 2 in - 16 out, BNC



Results:

1. Pulse shape

Fig 2b: Signal at the input of unit 2

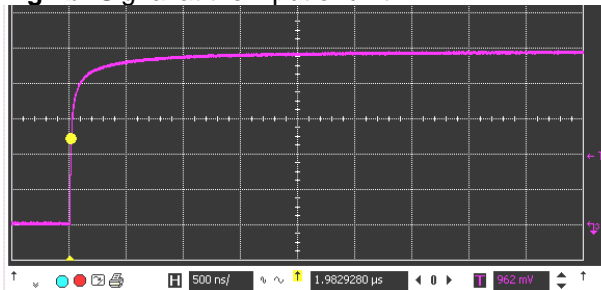

Horizontal scale: 500 ns/div (rise time 160 ns)
Vertical scale: 500 mV/div

Fig 2c: Signal at connector "OUT1" of unit 1 and unit 2.

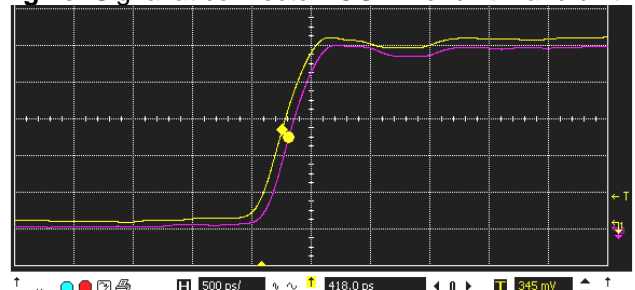

Horizontal scale: 150 ps/div (rise time 400 ps)
Vertical scale: 500 mV/div

2. Pulse jitter

Jitter with 310 m cable (FSJ1): <10 ps

3. Temperature coefficient

Temperature coefficient of 310 m cable (FSJ1) alone:	10 ps/K
Temperature coefficient of 2 units of 10545	12 ps/K
Total temperature coefficient over 310 m transmission:	<22 ps/K (incl. units)

Note:

Even better results can be expected with cables having less high frequency losses with foam dielectric, like Ecoflex 10, Ecoflex 15 or LDF4-50.

Pulse Distribution Unit



Part No: 10545

1PPS, to 200 MHz, 2 in - 16 out, BNC

Specification

Signal Inputs

Number of inputs	2 (BNC)
Signal type, input IN A (AC)	AC coupled input Sine wave: -10 dBm .. 16 dBm, 100 kHz to 20 MHz, output: 50 ± 2% duty cycle Square wave: 50 mV _{pp} .. 5V _{pp} (into 50 Ω), 1 kHz to 10 MHz, output 50 ± 2% duty cycle
Signal type, input IN B (DC)	DC coupled input Nominal: 1 pps, useable 1 Hz to 200 MHz, square wave, - logic one: min = 1 V, max = 5V - logic zero, nominal = 0V, tolerance = ±0.3V
Input impedance	50 Ω
Trigger level (0 → 1)	Selectable, IN A trigger level = 0V, IN B trigger level = 0.0 .. 2.5V
Significant slope	Positive
Conversion of sine to pulse	IN A (AC): input of pure sine wave => outputs square wave (positive) with 50 ± 2% duty cycle

Signal Output

Number of outputs	16 (BNC)
Output level	TTL (unloaded), 2.5 Vpp when loaded with 50 Ω
Output impedance	50 Ω
Significant slope	Positive, signal non-inverted
Pulse duration	same as input, continuous high level doesn't damage the unit
Rise / Fall time *)	≤ 500 ps (400 ps typ.) Between 10% and 90% points
Intrinsic jitter *)	≤ 2 ps
Output to output skew *)	≤ 20 ps (<10 ps typ.)
Equipment Delay *)	6.5 ns ± 0.5 ns
Temperature sensitivity *)	6 ps / K (10 °C to 50 °C)
*) measurement conditions: Input B: 1PPS signal, positive, 20 μs width, rise / fall time 400 ps, amplitude 2.5V pp loaded, input trigger level: 1.25V, output: loaded with 50 Ω	

Electrical interface

Power Consumption	< 15 Watt	
Supply Voltage AC	90 to 264 V AC, 50/60 Hz	Priority on AC supply input,
Supply Voltage DC	18 to 36 V DC, DC isolated	DC is used as back-up supply
2 redundant DC power input connectors, automatic switchover		
DC consumption when AC is ON: < 1 W (0.7W typ.)		
DC connector with 2 m cable included, IECV 61076-2-101 M8 (4 pins)		
(+) brown (1) & white (2), (-) blue (3) & black (4), polarity reversible		

Indicators

LED power input (green)	"Power present", one per power connector
LED signal input (green)	"Input signal present", one per input connector
LED power input (green)	"Power present", one per power connector
LED Alarm (red)	"no input present" or "one or more outputs failed"
Connector Alarm	Lo-Z: Nominal operation, all output pulses present
(Open Collector Output)	Hi-Z: no input pulse, unit failed, unit not powered, "Alarm RED"
Maximum voltage 5.5 V, (+) brown, (-) blue	
Alarm connector with 2 m cable included, IECV 61076-2-101 M8 (3 pins)	

Mechanical

Outline	19 inch, 1 height units (448.8 mm * 44 mm) depth 448 mm
Weight	5 kg

Environmental

Transportation and Storage	
Temperature.	-20°C to +75°C
Humidity	10% to 90% (non-condensing)
Altitude	< 12 000 m
Shock	max 10g acceleration for 11 ms
Vibration	max. 0.15 mm at 5 to 8 Hz, max 1g acceleration at 8 to 500 Hz
Operation	
Temperature	Operational 0°C to +50°C Full Spec +15°C to +45°C
Humidity	20% to 90% (non-condensing)
Altitude	< 2 000 m

Pulse Distribution Unit

Part No: 10545

1PPS, to 200 MHz, 2 in - 16 out, BNC

TIMETECH



Typical characteristics of Input A, (AC)

Input 10 MHz, 13 dBm sine, converted to 10 MHz square wave. Phase noise is shown in Fig 3a. .

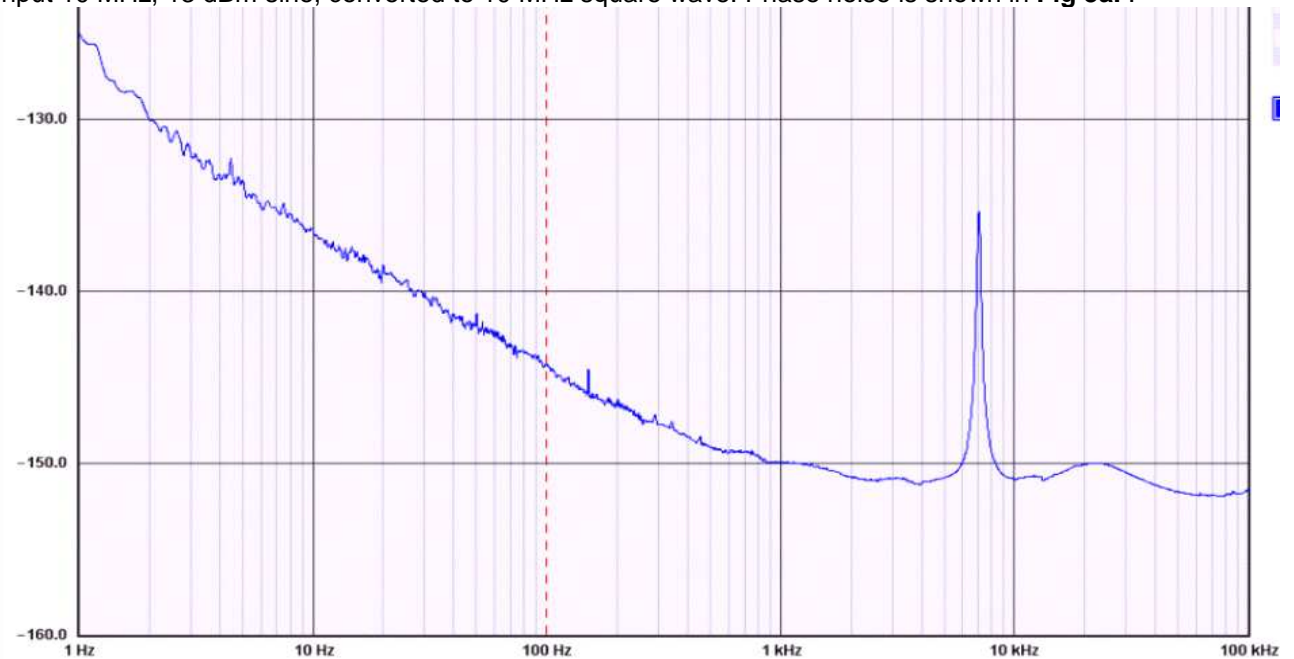

Fig 3a: Phase noise of 10 MHz square wave output, input 10 MHz sine input 13 dBm to input A.

Input 5 MHz, 13 dBm sine, converted to 5 MHz square wave. Phase noise is shown in Fig 3b.

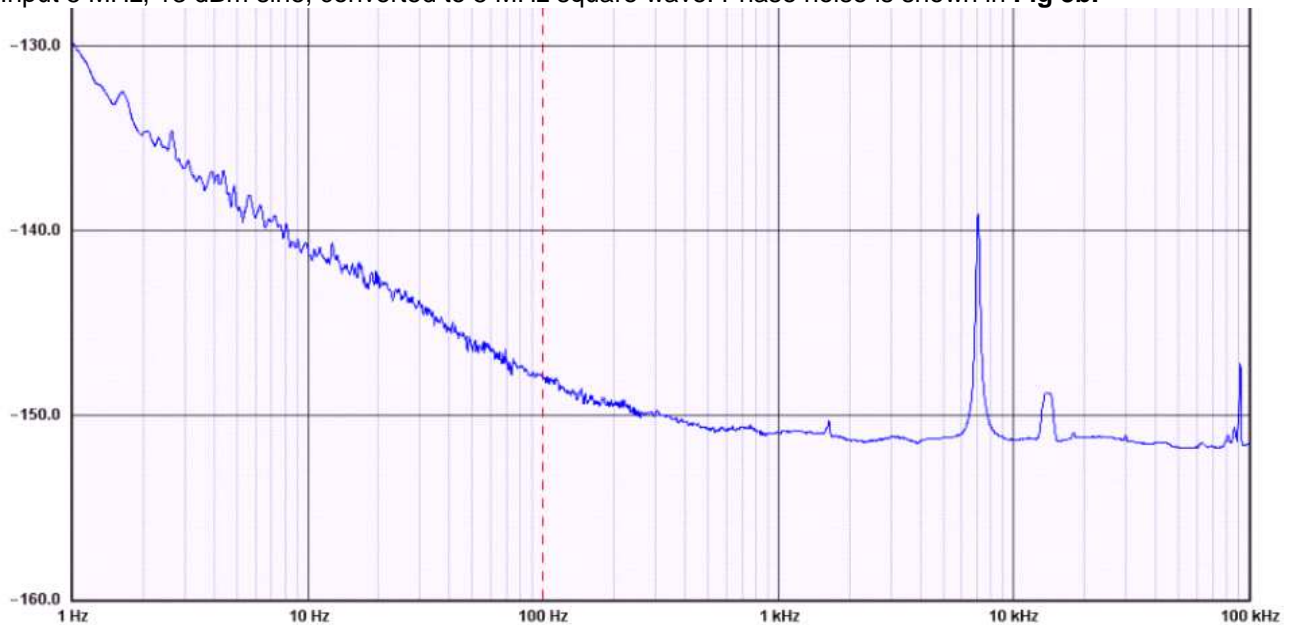

Fig 3b: Phase noise of 5 MHz square wave output, input 5 MHz sine input 13 dBm to input A.

Pulse Distribution Unit

Part No: 10545

1PPS, to 200 MHz, 2 in - 16 out, BNC



Typical characteristics of Input A, (AC), continued

Input A: Sine input, Output Jitter [ns] (rising edge)			
Frequency \ Input Level	10 dBm	0 dBm	-10 dBm
100 MHz	0,071	0,008	0,015
20 MHz	0,057	0,004	0,010
10 MHz	0,057	0,005	0,011
1 MHz	0,009	0,025	0,064
100 kHz	0,067	0,219	0,636
10 kHz	1,202	3,536	9,192
1 kHz	21,213	49,497	Not triggered

Table 3a: Output jitter [ns], sinusoidal signal to input A

Input A: Square wave input, Output Jitter [ns] (rising edge)			
Frequency \ Input Level	5 Vpp	1 Vpp	50 mVpp
50 MHz	0,002	0,004	0,024
20 MHz	0,002	0,004	0,025
10 MHz	0,001	0,004	0,034
1 MHz	0,001	0,004	0,023
100 kHz	0,002	0,004	0,023
10 kHz	0,002	0,004	0,021
1 kHz	0,002	0,004	0,020
500 Hz	0,002	0,004	Not triggered
100 Hz	0,003	0,005	Not triggered
90 Hz	Not triggered	Not triggered	Not triggered

Table 3b: Output jitter [ns], square wave signal to input A

Pulse Distribution Unit

Part No: 10545

1PPS, to 200 MHz, 2 in - 16 out, BNC

TIMETECH



Typical characteristics of Input B, (DC)

Conversion of sine to square coupled to input B, Input 100MHz, 7 dBm sine. Phase noise is shown in Fig 4a.

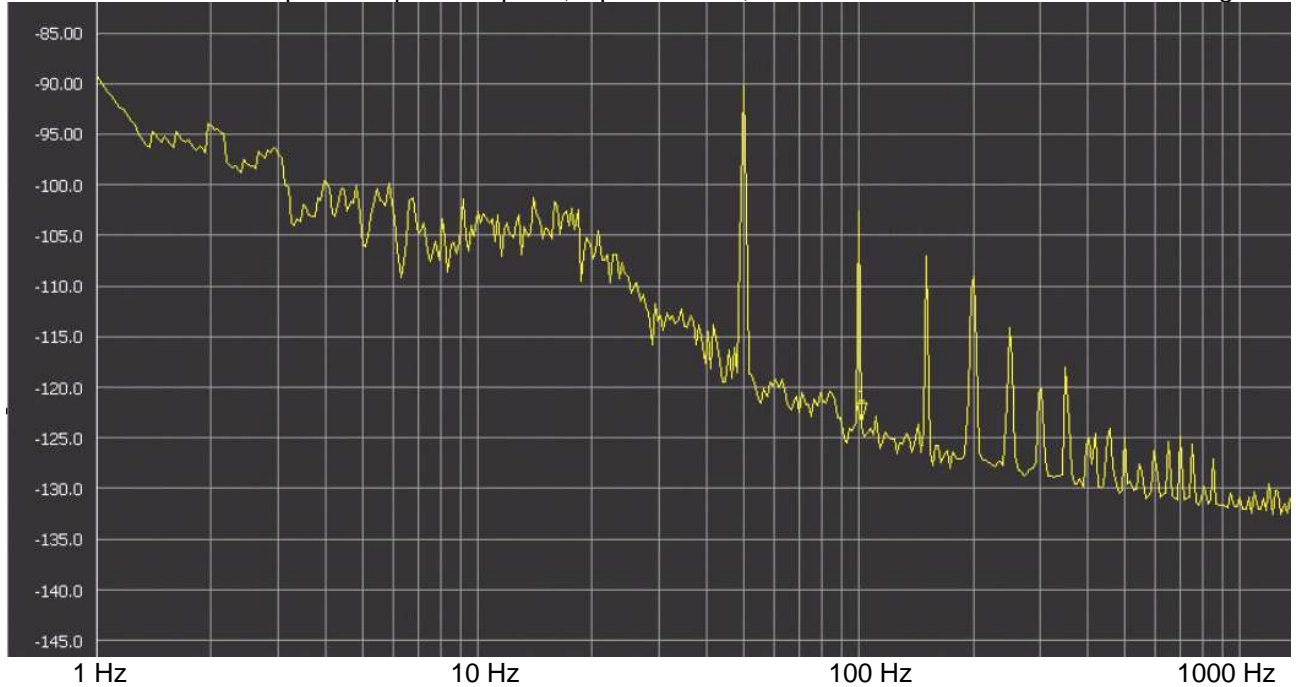

Fig 4a: Phase noise of 100 MHz square wave output, input 100 MHz sine, 7 dBm to input B, trigger 0V

Conversion of sine to square coupled to input B, Input 10MHz, 13 dBm sine. Phase noise is shown in Fig 4b.

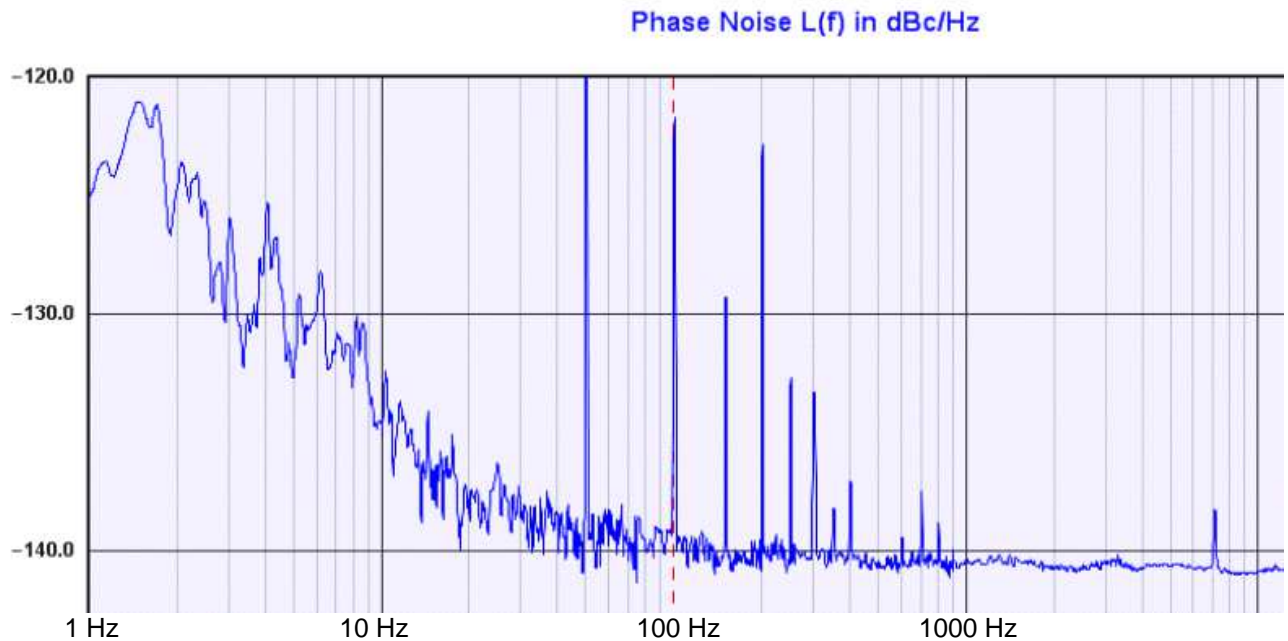

Fig 4b: Phase noise of 10 MHz square wave output, input 10 MHz sine, 13 dBm to input B, trigger 0V

Typical characteristics of Input B, (DC), continued

Conversion of sine to square coupled to input B, Input 5MHz, 13 dBm sine. Phase noise is shown in Fig 4c

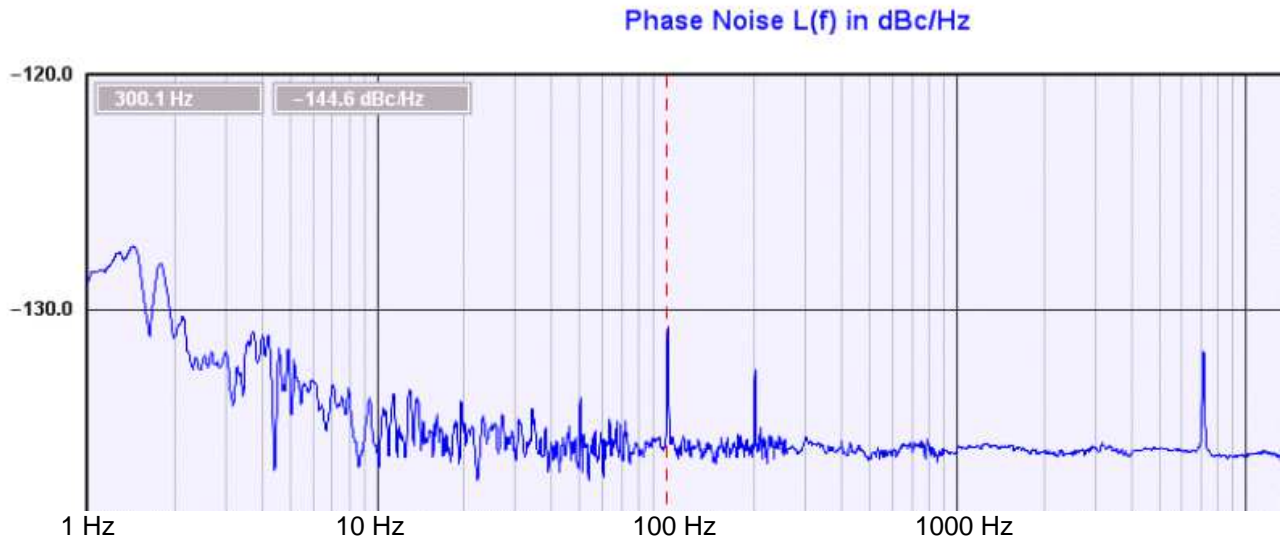

Fig 4c: Phase noise of 5 MHz square wave output, input 5 MHz sine, 13 dBm to input B, trigger 0V

As the IN B is DC coupled it works with arbitrary low frequency. Triggering is tested down to 1 mHz with an input signal amplitude of -10 dBm. The trigger works perfect with such low frequency and low signal level. The output jitter measured is in the order of

- 1E-4 x (signal period) at 10 dBm sine signal input level
- 1E-3 x (signal period) at -10 dBm sine signal input level

Typical results are shown in Figure 4d

Input B: Sinusoidal input, Output Jitter [ns] (rising edge)					
Frequency \ Input Level	10 dBm	0 dBm	-10 dBm	Trigger	
10 MHz	0,01	0,04	0,11	OK	
1 MHz	0,11	0,30	0,71	OK	
100 kHz	0,70	2,12	6,00	OK	
10 kHz	6,00	18,00	53,00	OK	
1 kHz	46,00	142,00	460,00	OK	
100 Hz	475,00	1200,00	4243,00	OK	
10 Hz				OK	
1 Hz				OK	
100 mHz			4245000,00	OK	
10 mHz				OK	
1 mHz				OK	

Fig 4d: Output jitter using input B and sinusoidal input signal. Trigger level 0V. Input Signal is DC coupled.

Pulse Distribution Unit

Part No: 10545

1PPS, to 200 MHz, 2 in - 16 out, BNC

TIMETECH



Unit Outline

Front View

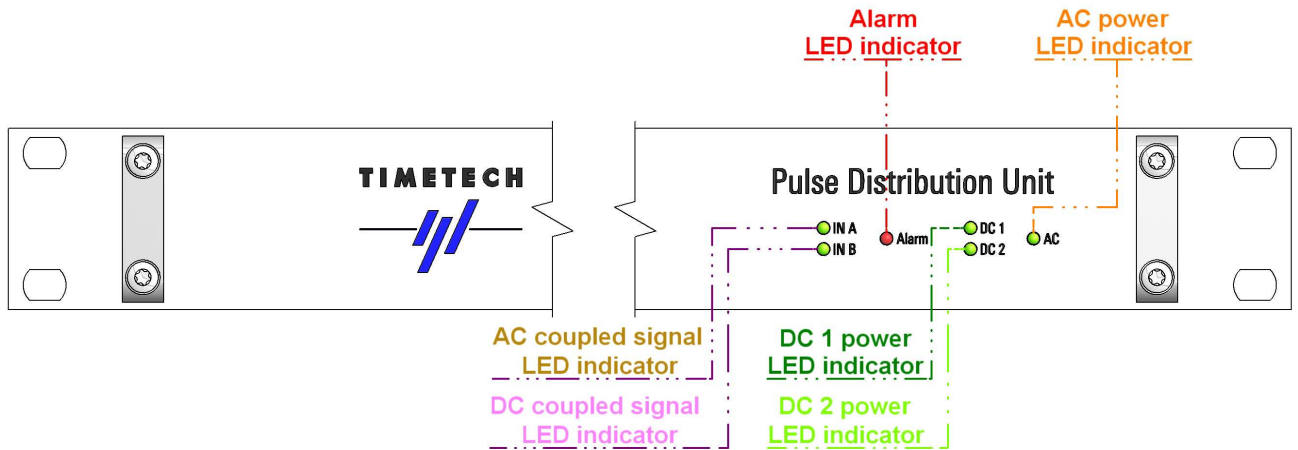

Rear View

